

GENERAL CIRCULATION

Contents

Energy Cycle
Mean Characteristics
Momentum Budget
Overview

Energy Cycle

R Grotjahn, University of California, Davis, CA, USA

Copyright 2002 Elsevier Science Ltd. All Rights Reserved.

doi:10.1006/rwas.2002.0155

Grotjahn, R

University of California,
 Department of Land, Air, and Water Resources,
 Davis, CA 95616-8627, USA

Introduction

The energy cycle provides a physically meaningful system through which to understand the many constraints and properties of the general circulation. Energy is conserved and can be tracked even as it changes from one form to another. Energy properties can be analyzed to deduce the strengths of circulations, as well as the rates at which circulations are created, maintained, or destroyed.

The total energy (TE) is defined by the relationship:

$$\underbrace{C_v T + gZ}_{\text{DSE}} + Lq + \underbrace{1/2(u^2 + v^2 + w^2)}_{\text{KE}} = \text{TE} \quad [1]$$

MSE

where C_v is the specific heat capacity at constant volume, T is the temperature, g is the acceleration due to gravity, Z is the geopotential height, L is the latent heat of vaporization or sublimation, q is the specific humidity, and u , v , and w are eastward, northward, and upward wind components. The term $C_v T$ represents internal energy, gZ gravitational energy, Lq latent energy from the phase changes of water, and $\frac{1}{2}(u^2 + v^2 + w^2)$ the kinetic energy (KE). Together the first two terms define the dry static energy (DSE), while including the third defines moist static energy (MSE).

Potential energy (PE) is usually defined as DSE. A tiny fraction of the PE, called the available potential

energy, APE, can be used to drive the KE. The concept of APE is used to explain the links between PE and KE and is usually defined as the difference between the PE and the minimum PE that could be achieved by an adiabatic arrangement of mass. Sometimes latent heating is included directly in the APE, but usually it is treated as a separate diabatic process. PE is useful for global energy balance.

Solar radiant energy does not reach the Earth equally everywhere. On average, the tropics receive and absorb far more solar energy annually than the polar regions. This distribution of absorbed energy creates an uneven distribution of temperature. Temperature, pressure, and density are related, so the PE has an uneven distribution too. The existence of APE is essentially due to the horizontal variations in density and temperature. APE leads to motions (KE) as the atmosphere tries to remove these density and temperature variations. The motions redistribute some mass, but mainly the atmosphere transports heat. The atmospheric circulation becomes a complex balance between the radiant energy input and output that creates the APE needed to generate the KE of circulations, which in turn strive to create a state of no APE.

Available potential energy and KE are defined in formal mathematical ways. The mathematics shows interactions from which physical mechanisms (such as baroclinic instability) can be identified. The energy equations describe the following chain of events. Radiation creates APE; some APE is converted to motions that redistribute the heat energy; KE in turn is lost by conversion back to APE and by friction. The forms of energy and the "net" conversions between them can be represented via a "box" diagram. However, the box diagram does not show the energy cycle in an intuitive sense. To make the physical mechanisms clear, energy must be examined regionally and one phenomenon at a time.

Conceptual Models

Two-fluid Model

0155-P0030 A fluid flow analog of the pendulum can illustrate forms and conversions of energy. Imagine a tank holding two fluids of different density, separated by a vertical barrier (Figure 1A). The initial state has the highest center of mass and thus the greatest gravitational PE. If the barrier is suddenly removed, the fluids begin to move. The motion accelerates until the point in time where the greatest amount of the denser fluid underlies the greatest amount of the less dense fluid (Figure 1B). The center of mass is now at its lowest, as is the gravitational PE. Ignoring friction, mixing, and turbulent effects, KE is maximized at this point. As time proceeds further, the fluids overshoot this state, and KE begins converting back to PE (Figure 1C).

0155-P0035 APE is defined as the difference between the current PE and the minimum PE. The state with lowest PE is the “reference state”, which has zero APE. The reference state definition is somewhat arbitrary. Another mechanism could possibly occur at some later time to lower further the minimum PE, for example a net temperature decrease. However, the size of the conversions, generation, and destruction are not arbitrary. APE is intended to represent the PE available for driving motions, so the reference state is usually defined by rearranging atmospheric properties in the horizontal dimensions so as to reach a state of minimum PE. This model reveals that density differences across a fixed elevation in the tank are proportional to the APE.

0155-P0040 The model relates to the atmosphere as follows.

1. Temperature differences create the density differences. The less dense fluid represents the tropics; the denser fluid represents polar regions.
2. The reference state has minimum center of mass when the air “layers” are flat. Flat fields of pressure and temperature imply no geostrophic or ageostrophic winds.
3. Density differences (sloping air “layers”) have APE but also produce horizontal pressure gradients that

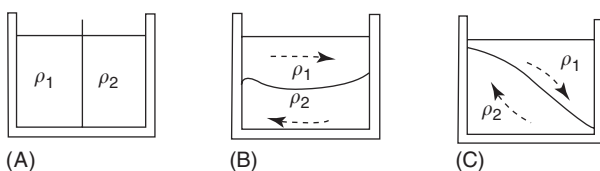

0155-F0001 **Figure 1** Schematic model of fluid motion showing APE and KE concepts. The tank holds two immiscible fluids with density $\rho_1 < \rho_2$. (A) Initial state; (B) state with maximum KE but minimum PE reached during the first oscillation; (C) state where KE is being converted back to PE.

accelerate the air. On the rotating Earth, geostrophic winds, and thus KE, are also present. So, reservoirs, sources, and sinks of APE are not independent of KE.

Carnot Cycle

The Carnot cycle can be used to estimate KE generation from thermodynamic changes that an air parcel undergoes while completing an atmospheric circuit. The Hadley cell is a conceptual model for the zonal mean tropical circulation. Air in the lower troposphere moves equatorward while gaining heat and moisture from surface fluxes. Near the Equator rapid ascent within thunderstorms releases and advects much latent heat energy. Reaching the upper troposphere, air moves poleward, cools radiatively, and sinks, completing a circuit.

Kinetic energy generation can be estimated by plotting the thermodynamic properties of air parcels on a skew T - $\log P$ chart. A unit area anywhere on the chart corresponds to a specific amount of energy exchange. Figure 2 shows a realistic circuit around an annual mean Hadley cell. The amount of APE converted to KE by a kilogram of air while it completes the plotted circuit is $E \sim 1.4 \times 10^3 \text{ J kg}^{-1}$.

The rate of energy release per unit horizontal area, R , by all the air in motion, can be compared to the rate per unit area of energy absorbed from the Sun:

$$R = MEt^{-1}A^{-1} \quad [2]$$

where M is the mass in motion, t is the time to complete the circuit, and A is the area of the Hadley cell. For the schematic circulation indicated in Figure 2A, $M \approx 10^{18} \text{ kg}$, $A \approx 10^{14} \text{ m}^2$, and $t \sim 3 \times 10^6 \text{ s}$. The total rate of energy released by the Hadley cell is $MEt^{-1} \approx 5 \times 10^{14} \text{ J s}^{-1}$. However, the rate per unit area is only $R \sim 3.6 \text{ W m}^{-2}$. The absorbed solar radiation in the tropics is 100 times larger than R , making the atmosphere an “inefficient” heat engine. (Efficiency of the Carnot cycle is often measured in a way dependent on the temperature, but our estimate is related to energy input.)

The model illustrates these properties:

1. Warmer air is rising and cooler air is sinking so the center of mass is lowered and KE is created; the circuit is counterclockwise and the circulation is “thermally direct.” In contrast, the Ferrel cell is a clockwise circuit that reduces KE to increase PE.
2. A steady state is reached if the frictional losses balance the KE generation.
3. The rate of KE generation depends on the area enclosed by the circuit divided by the time to complete the circuit.

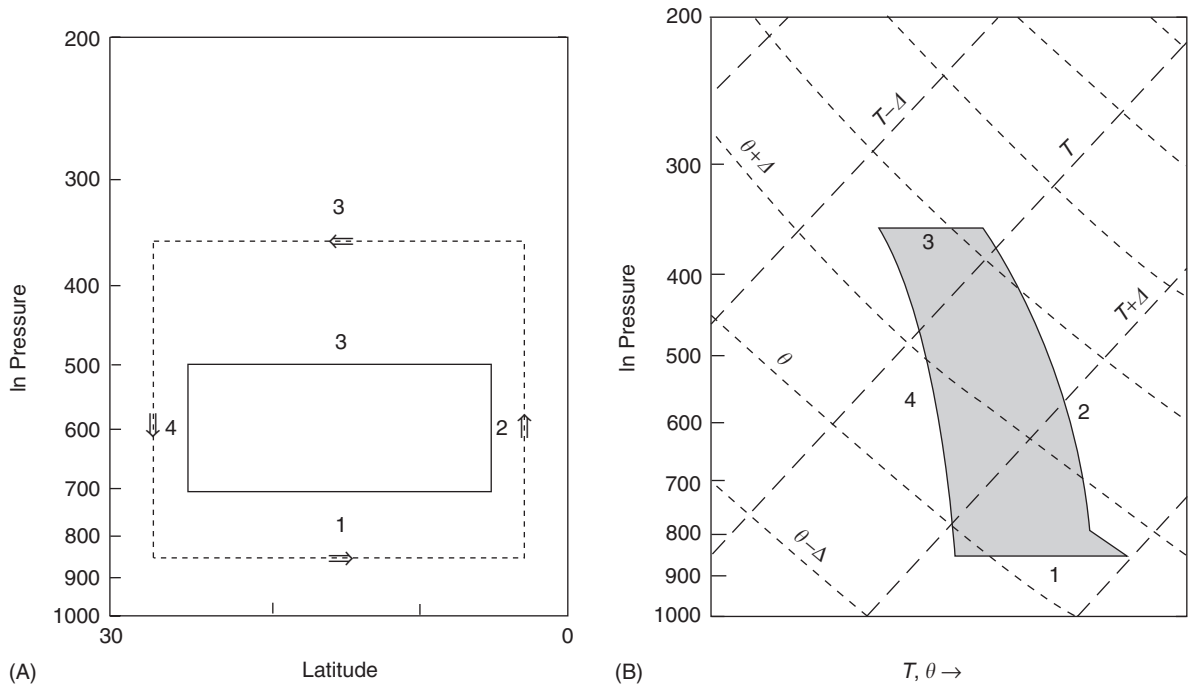

0155-F0002 **Figure 2** Interpretation of the Hadley circulation as a Carnot cycle. (A) Meridional cross-section showing the idealized circulation. The dashed line shows an average path followed by the parcels with numeric labels for each leg. (B) Skew T - $\ln P$ plot of the thermodynamic changes along each of the four legs drawn in part (A). The shaded area is proportional to the energy converted from PE to KE.

4. The amount of energy converted is proportional to a circuit integral of T , so it increases as the temperature difference increases between the warm and cold stages of the cycle. During winter the meridional temperature gradient is stronger than summer, and so is the Hadley cell.
5. In winter, the air motion of the Hadley cell is 5–7 times stronger than that of the Ferrel cell but larger temperature differences occur along the Ferrel circuit. So, the net energy conversions are similar (see ‘The Box Diagram’ below).
6. Large energies are involved, but only a tiny fraction of the solar radiation actually drives the observed motions.
7. The path followed by air parcels was specified, not predicted.

Available Potential Energy

0155-P0065 Available potential energy is approximated by temperature variations on a pressure surface:

$$APE = \int \varepsilon C_p T dM$$

$$\approx \frac{1}{2} \kappa C_p P_{00}^{-\kappa} \int P^{\kappa-1} \{ \overline{\theta - \bar{\theta}} \}^2 \left(\frac{\partial \theta}{\partial P} \right)^{-1} dM \quad [3]$$

$$\varepsilon = 1 - \left\{ \frac{P_r}{P} \right\}^\kappa \quad [4]$$

where M is mass, θ is potential temperature, $P_{00} = 10^5$ Pa, C_p is the specific heat capacity at constant pressure, $\kappa = R C_p^{-1}$, R is the ideal gas constant, and ε is the “efficiency factor.” $P_r(\theta)$ is the reference pressure, which is the average pressure on a potential temperature surface θ . Available potential energy is zero when $P = P_r$ everywhere in the domain. The overbar denotes the horizontal average on an isobaric surface.

1. For an integral over the depth of the atmosphere, APE differs from PE by the factor ε .
2. Observed PE is about a thousand times greater than estimates of global average APE.
3. Hemispheric PE is greater in summer since the air is generally warmer than in winter.
4. Hemispheric APE is greater in winter when the meridional temperature gradient is stronger, making the term in curly bracket $\{ \}$ larger than in summer. The further the atmosphere departs from the reference state mean, the larger ε becomes.
5. Diabatic heating or cooling can create APE if it magnifies the departures but the same heating or cooling can destroy APE if it reduces the departures. In simplistic terms, APE is generated by “heating where it is hot or cooling where it is cold.”
6. $\varepsilon > 0$ in “hot” regions and $\varepsilon < 0$ in “cold” regions. From Figure 3, ε has a positive maximum in

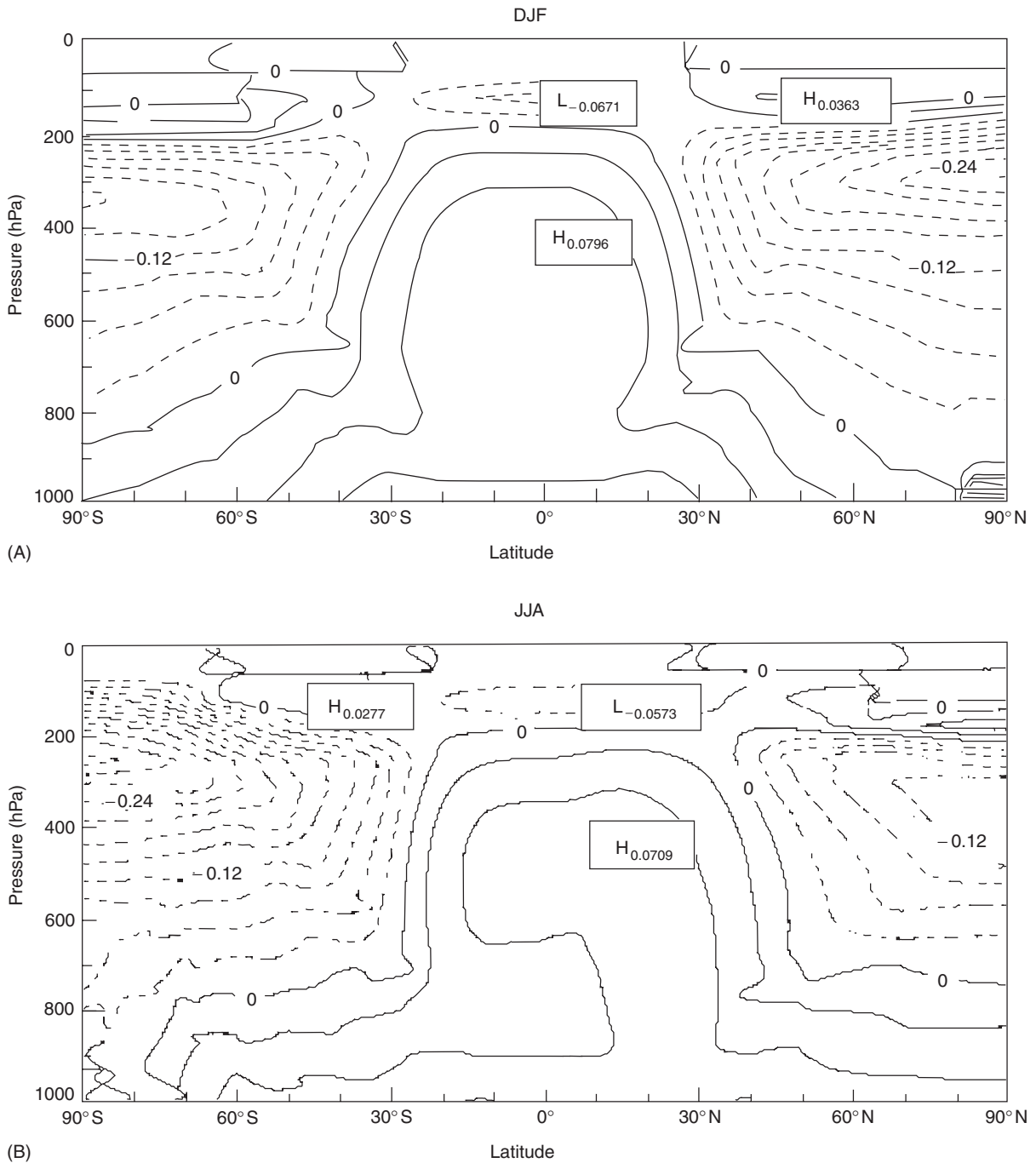

0155-F0003 **Figure 3** Zonal mean efficiency factor $[\varepsilon]$ for (A) December–February and (B) June–August. $[\varepsilon]$ is estimated from zonal mean 1979–99 National Center for Environmental Prediction/National Center for Atmospheric Research (NCEP/NCAR) reanalysis data. The contour interval is 0.03.

the tropical middle troposphere and negative minima in high latitudes. In middle latitudes the sign varies with longitude: $\varepsilon > 0$ over oceans during winter or warm sectors of frontal cyclones while $\varepsilon < 0$ over continents in winter or behind cold fronts.

Kinetic Energy

Kinetic energy is primarily contained in horizontal winds:

$$KE = 1/2 \int (u^2 + v^2) dM \quad [5]$$

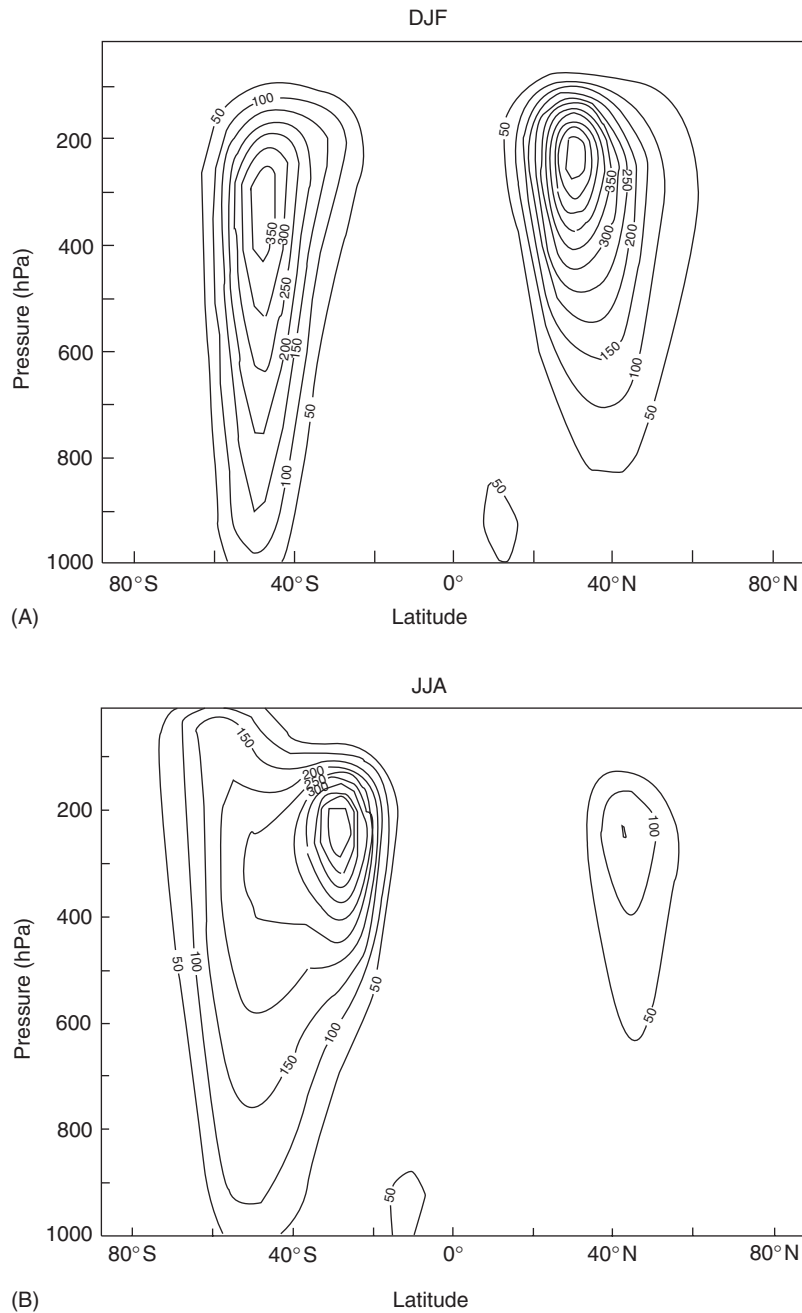

0155-F0004 **Figure 4** Zonal mean kinetic energy density for (A) December–February and (B) June–August using 1979–99 NCEP/NCAR reanalysis data. The contour interval is $50 \text{ kg s}^{-2} \text{ m}^{-1}$.

0155-P0075 Kinetic energy has the following properties:

down easterlies increases westerly momentum, but reduces KE.

1. The distribution of zonal mean KE (Figure 4) has maxima at upper levels near the subtropical jets.
2. Kinetic energy is related to atmospheric momentum and torque. Momentum fluxes by the Hadley cells and by midlatitude eddies maintain the KE maximum near the subtropical jet. However, slowing

Energy Generation and Conversion

Energy Equations

To understand how energy evolves one needs formulae for APE and KE tendencies in a limited domain. The

domain may be a unit area in the meridional plane (useful for calculating zonal means) or enclosing a single phenomenon to the exclusion of others (e.g., a single frontal cyclone). Tendency equations for APE (A_e) and KE (K_e) in a mass M between two isobaric surfaces are:

$$\begin{aligned} \frac{\partial A_e}{\partial t} = & \underbrace{\int (\varepsilon q) dM}_a + \underbrace{\int (\varepsilon \omega \alpha) dM}_b \\ & - \underbrace{\int \varepsilon \nabla_p \cdot (V_p C_p T) dM}_c \\ & + \underbrace{\int \left(C_p T \frac{\partial \varepsilon}{\partial t} \right) dM}_d \end{aligned} \quad [6a]$$

$$\begin{aligned} \frac{\partial K_e}{\partial t} = & - \underbrace{\int (V_p \cdot F) dM}_a - \underbrace{\int (V_p \cdot \nabla_p \Phi) dM}_b \\ & - \underbrace{\int \nabla_p \cdot (V_p K_e) dM}_c \end{aligned} \quad [6b]$$

where q contains all diabatic heating and F is friction. Here V_p and ∇_p dense velocity and gradient evaluated in isobaric coordinates.

The terms are ordered to match similar processes. Term “a” in each equation has diabatic source/sink mechanisms. Term “b” is similar but has opposite sign in the A_e and K_e equations and so represents a (baroclinic) conversion between these two forms of energy. Term “c” is divergence of potential or kinetic energy flux; it is a conversion between the APE or KE inside and external to the domain; baroclinic or barotropic conversions respectively, appear in this term.

Diabatic Sources and Sinks of Energy

There are five categories of diabatic processes: solar and terrestrial radiation, latent and sensible surface heat flux, and friction. Figure 5 illustrates how these are distributed on a zonal mean.

1. *Solar radiation absorbed.* Much more radiation is absorbed ($q > 0$) in the tropics ($\varepsilon > 0$) than in polar regions ($\varepsilon < 0$), so APE is generated, particularly in the winter hemisphere.
2. *Terrestrial radiation emitted.* The emission ($q < 0$) is greater in the tropics, suggesting destruction of APE. But APE is generated because the emission in high latitudes is from cloud tops where ε is strongly negative. In the less cloudy subtropical latitudes,

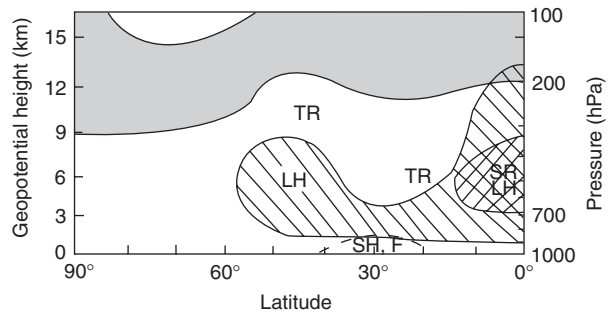

Figure 5 Schematic distribution of the primary sources of diabatic heating. Solar radiation (SR) heating rate is greatest near the equatorial lower troposphere. Cross-hatching indicates $SR > 1 K d^{-1}$. The area with terrestrial radiation (TR) cooling rate magnitude $< 1 K d^{-1}$ is shaded. Terrestrial radiation labels are placed where relative extremes of cooling occur. Latent heat is released in the lower and middle troposphere in regions where rainfall is relatively heavier, with relative maxima indicated by the latent heat label (LH). The area with LH exceeding $1 K d^{-1}$ is marked with hatching bounded by a chain curve. Surface sensible heat flux exceeds $1 K d^{-1}$ (dashed line) in the subtropics.

emission mainly occurs where ε has smaller magnitude.

3. *Latent heat surface flux.* Evaporation introduces water vapor into the atmosphere. The latent heat is released where condensation occurs, which may be quite distant. In the tropics, much latent heat is released in the middle troposphere (mainly in the intertropical convergence zone, ICZ) where $\varepsilon > 0$. Evaporation is enhanced in middle latitudes near the east coasts of continents during winter: very dry surface air in the cold sector of a frontal cyclone blows over warm waters of an oceanic western boundary current (WBC) such as the Gulf Stream. This air is warmed and moistened, often becoming the warm sector of the following storm. While the evaporation occurs in the storm’s cold sector, the latent heating occurs in the warm sector, and eddy APE is likely generated.
4. *Sensible heat surface flux.* Also largest near a midlatitude WBC, sensible heating is input into the colder air, thus destroying the temperature contrast between the warm and cold sectors of the extratropical cyclone. While APE destruction is anticipated, sensible heating does lower the static stability, which allows vertical motions to proceed more freely encouraging baroclinic conversion.
5. *Friction.* Friction is only important for KE and it always destroys KE.

Baroclinic Conversions

It is not obvious that terms ‘b’ in eqn [6] are conversion between APE and KE in the limited volume energy

equations. Using the hydrostatic and continuity equations:

$$V_p \cdot \nabla_p \Phi = \omega \alpha + \nabla_3 \cdot (V_3 \Phi) \quad [7]$$

For a closed system, there is no mass divergence, and the pressure work term $(\nabla_3 \cdot (V_3 \Phi))$ vanishes. For an open system, $V_p \cdot \nabla_p \Phi \ll \nabla_3 \cdot (V_3 \Phi)$. Since $\varepsilon \ll 1$, $\varepsilon \omega \alpha$ has comparable magnitude to $V_p \cdot \nabla_p \Phi$.

Two approximate forms of this conversion aid interpretation of the process. For a closed system, as illustrated in **Figure 6**, the conversion depends on the difference in thickness above the surface high (H_H) and surface low (H_L):

$$-Sg|\omega| (H_H - H_L) \sim V_p \cdot \nabla_p \Phi \quad [8]$$

where S is the horizontal area for each half of the domain and $|\omega|$ is the magnitude of the mean ω . Since thickness is proportional to the mean temperature of the layer of air, the sign and magnitude of the conversion depend on vertical motion in relatively warmer and colder regions. In **Figure 6A**, warm air over the surface low rises while cold air sinks, causing cyclogenesis (APEKE). In **Figure 6B**, warm air overlies the surface high, causing cyclolysis. The magnitude of the conversion during the developing stage exceeds that during the decay stage, implying net generation of KE.

A simple description the baroclinic conversion is “warm air rising or cold air sinking converts APE into KE”. The relationship is seen in the quasi-geostrophic system, where

$$-\omega \alpha \approx g \mu W \theta$$

and $\mu \ll 1$ is a nondimensionalizing constant. The Carnot cycle model illustrates this mechanism, as does the conversion of zonal mean APE (A_Z) to zonal mean KE (K_Z) found in tropical Hadley cells. In middle

latitudes zonally varying phenomena (eddy) dominate the circulation.

To drive these midlatitude eddies two conversions are incorporated into the “baroclinic” conversion label: A_Z to eddy APE (A_E) and A_E to eddy KE (K_E). The latter is proportional to a vertical eddy heat flux, while the former is proportional to a horizontal eddy heat flux. From thermal wind balance, the environment has a meridional temperature gradient and westerly vertical shear. Eddy horizontal heat fluxes are directed down the temperature gradient (towards the pole) if the eddy tilts against the vertical shear. The upstream tilt and vertical heat flux are both visible in the schematic diagram show in **Figure 6A** of cyclogenesis.

Figure 7 shows the observed zonal mean heat flux by all motions. In the tropics the heat flux follows the Hadley cell: equatorward, then upward, then poleward, and finally sinking in the subtropics. The heat is then advected poleward, mainly by eddies.

Barotropic Conversion

The barotropic mechanism rearranges KE. A commonly shown redistribution is between the zonal mean and eddy KE. In the KE tendency equation, this conversion depends on eddy momentum fluxes as well as on the mean flow horizontal shear. Zonal mean KE is generated where eddy momentum fluxes are up the gradient of the mean flow.

The eddy momentum fluxes, meridional cells, and jets are linked in the barotropic mechanism. Meridional momentum transport (**Figure 8**) by the Hadley cell is up the gradient of the zonal mean subtropical jet streams. The meridional cells have little meridional motion at the subtropical jet, but the eddies carry momentum further poleward. In midlatitudes the Ferrel cell momentum flux opposes the flux by the eddies.

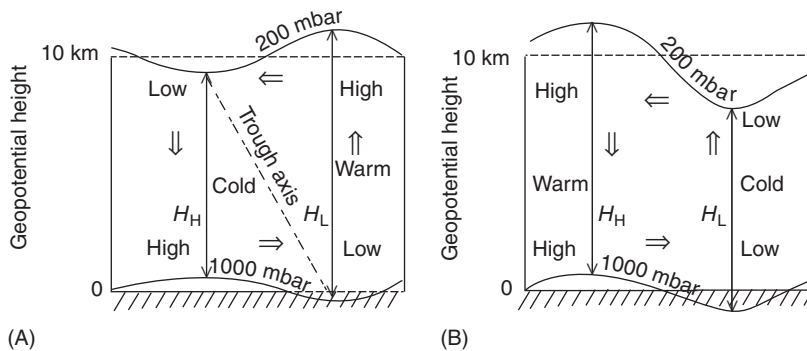
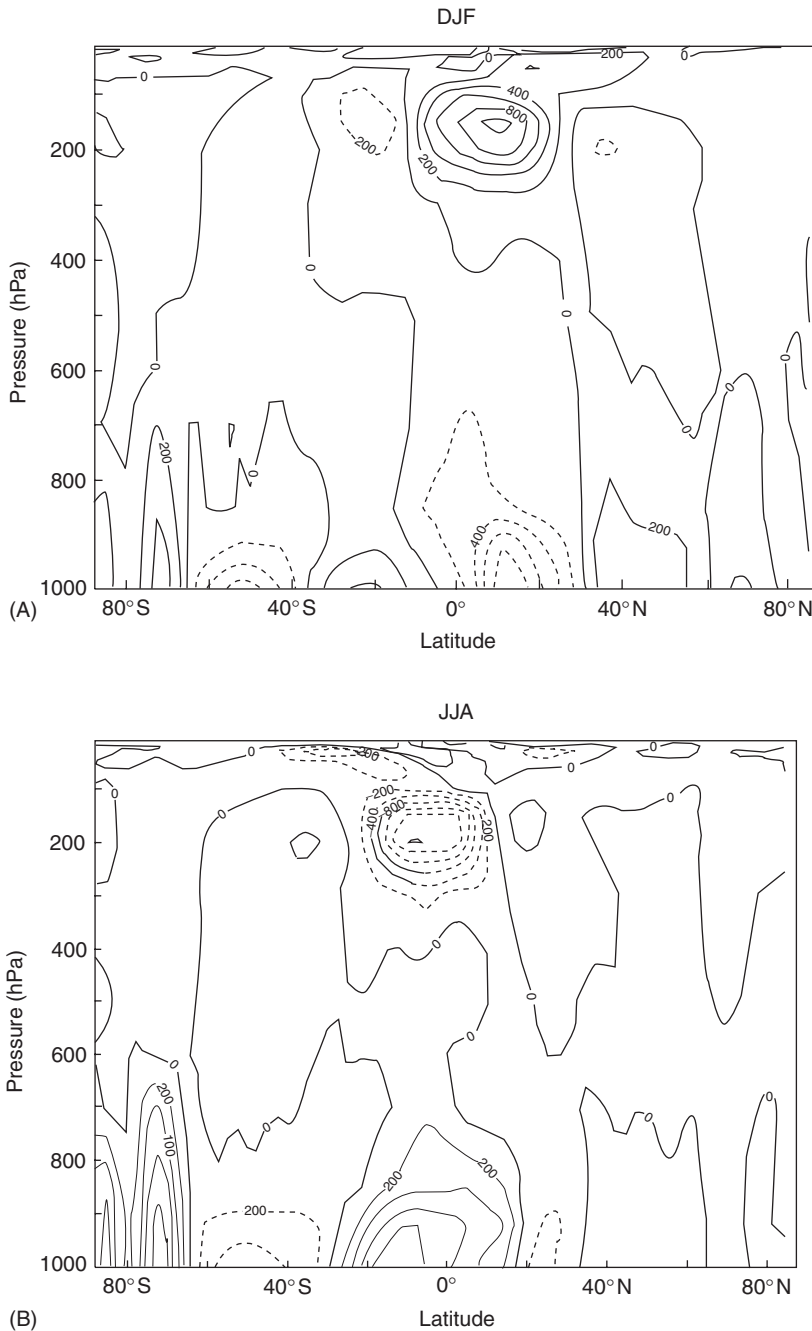

Figure 6 Highly idealized schematic illustration of a midlatitude frontal cyclone during (A) baroclinic growth and (B) baroclinic decay. The 1000 and 200 mbar surfaces are marked. Areas of relatively warmer and colder air at an isobaric level are noted. Double-shafted arrows indicate the relevant part of the ageostrophic circulation. The dot-dashed line in (A) shows the trough axis through the troposphere.



0155-F0007 **Figure 7** Zonal mean meridional flux of potential temperature $[v\theta]$ for (A) December–February and (B) June–August using 1995–99 NCEP/NCAR reanalysis data. Hadley cell fluxes are apparent in the tropics, while eddy fluxes predominate in midlatitudes.

0155-P0130 Complexity arises from several sources.

1. The eddies have preferred regions of genesis and decay and their momentum fluxes vary greatly between these regions.
2. Mature lows migrate to the cold side of the jet and thus deflect the jetstream equatorward.
3. Eddy momentum fluxes build vertical shear while the eddy heat fluxes reduce the temperature gradi-

ent, a combination that opposes thermal wind balance. One consequence is the formation of a secondary circulation, appearing as the “Ferrel cell” on a zonal average, which partially opposes the eddy heat and momentum fluxes. This Ferrel cell brings westerly momentum downward. Thus the jet streams are equatorward of where the eddy momentum flux has greatest convergence.

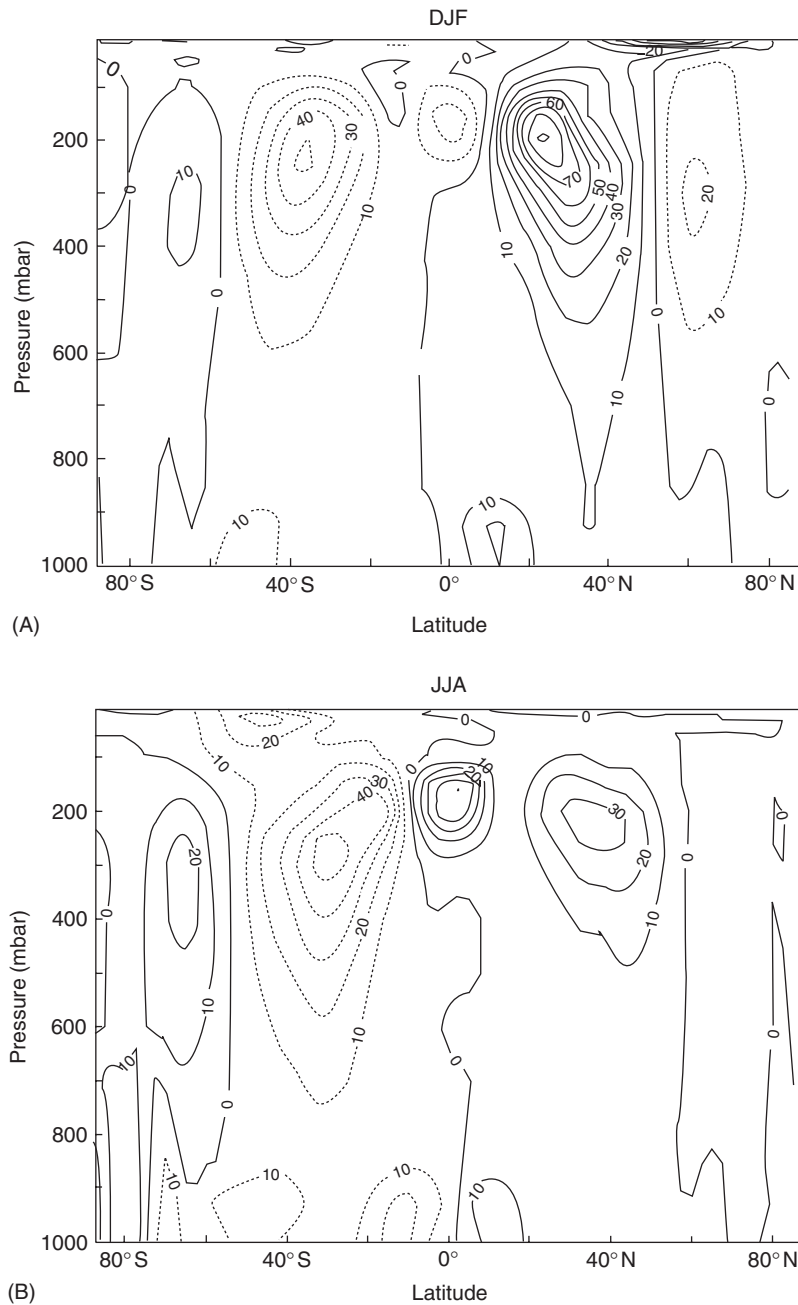

(A)

(B)

Figure 8 Zonal mean meridional flux of zonal wind $[v u]$ for (A) December–February and (B) June–August using 1995–99 NCEP/NCAR reanalysis data. Hadley cell fluxes are apparent in the tropics, while eddy fluxes predominate in midlatitudes.

The eddies need horizontal tilts (see **Figure 9**) to accomplish the observed momentum fluxes.

Summary Depictions

Global Energy Balance

Ignoring seasonal and climatic heating that can occur, there should be a balance between the solar energy absorbed by the Earth and that radiated away into space. The actual energy budget between Earth and

space depends on a variety of factors including cloud cover, atmospheric composition, and surface properties. Estimates for the Earth's surface and atmosphere on global and annual averages are presented in **Figure 10**.

Some limitations of this summary depiction are:

- Net radiation (solar minus terrestrial) is positive from 38° N to 38° S and negative elsewhere. The balance shown is global, so net radiation is zero.

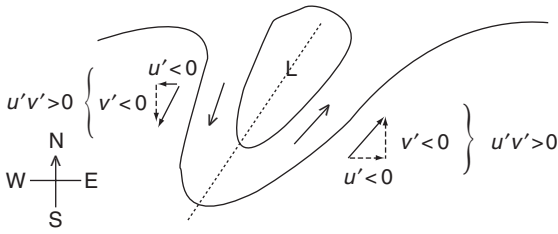

0155-F0009 **Figure 9** Schematic illustration of how a horizontal tilt of the trough axis (dotted line) leads to a net meridional transport of eddy zonal momentum. Primes denote winds with the zonal average removed. In this case the zonal average eddy momentum flux is northward. In contrast, a low that is symmetric about a north–south axis has $u'v'$ contributions on the east and west sides that cancel in the zonal mean.

- Heat fluxes sustain the net radiation pattern; those motions are not included.
- Vertical fluxes of heat and radiation are not shown; **Figure 10** shows only the net transfer for the whole atmosphere.

0155-P0150 From **Figure 10** it can be seen that:

- Solar (shortwave) radiation can be treated separately from terrestrial (longwave) energy.
- The (shortwave) albedo is greatly affected by clouds, which also strongly affect terrestrial emission.
- More solar radiation is absorbed by the ground (50%) than by the air (20%).
- The solar radiation reaching the ground evaporates water, is emitted as longwave radiation, or creates a sensible heat flux.
- The net surface emission must balance the input (21 units) not lost by surface fluxes. However, the actual surface longwave emission (116 units) exceeds the shortwave input because of downward radiation

from the atmosphere; this is known as the “greenhouse” effect.

The Box Diagram

The sources and sinks of energy discussed above can be summarized for the atmosphere using the “box” diagram. Each box is one form of energy. Arrows indicate input and output from each box as identified in the energy equations. Energy is converted back and forth between various forms, but only net changes are shown. The Hadley circulation is contained in the zonal mean quantities at the top row of the box diagram. Midlatitude frontal cyclones are included in the bottom row.

0155-P0155

The box diagram has some limitations:

0155-P0160

- The distribution and properties are missing. For example, A_Z to A_E is largest mainly in middle latitudes
- Only net changes are shown, whereas large regional variations occur. A_Z to $K_Z > 0$ for the Hadley cells but < 0 for Ferrel cells. Some studies show this net conversion as negative.
- Some conversions are simultaneous, as mentioned above, especially the A_Z to A_E to K_E route by which frontal cyclones intensify.
- Some conversions are hard to measure directly and are either approximated (e.g., A_Z to K_Z) or deduced as a residual (e.g., G_E and A_E to K_E).

Observed reservoirs, conversions, sources, and sinks are depicted in **Figure 11**. Diabatic processes create much A_Z , which in turn drives K_Z of zonal mean circulations such as the Hadley and Ferrel cells and the zonal mean midlatitude westerlies. Some A_Z is converted to A_E , which becomes K_E , especially in midlatitude frontal cyclones. Convergence of eddy momentum is a net conversion of K_E to K_Z . Since

0155-P0165

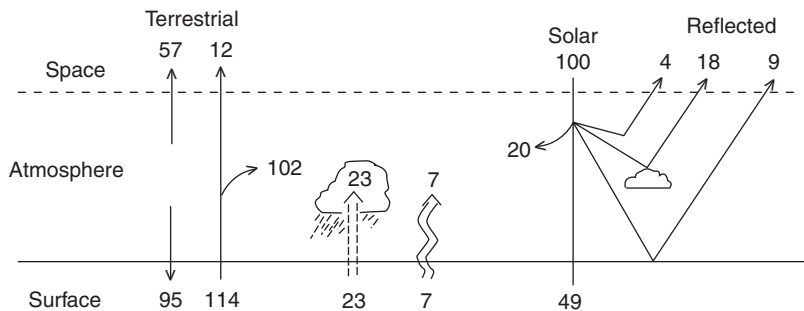

0155-F0010 **Figure 10** Global average energy balance expressed as percentages of the solar radiation striking the top of the atmosphere. Estimates of the solar constant vary, but the 100 units in the figure correspond to $\sim 342 \text{ W m}^{-2}$. Right side: solar radiation processes showing amounts reflected and absorbed. Middle: surface sensible heat flux (wavy arrow) and surface latent heat flux (dashed arrow). Left side: terrestrial radiation processes showing emission, transmission, and absorption. (Data in the figure come from several sources, but primarily from Kiehl J and Trenberth K, (1997) *Bulletin of the American Meteorological Society* 78: 197–208.)

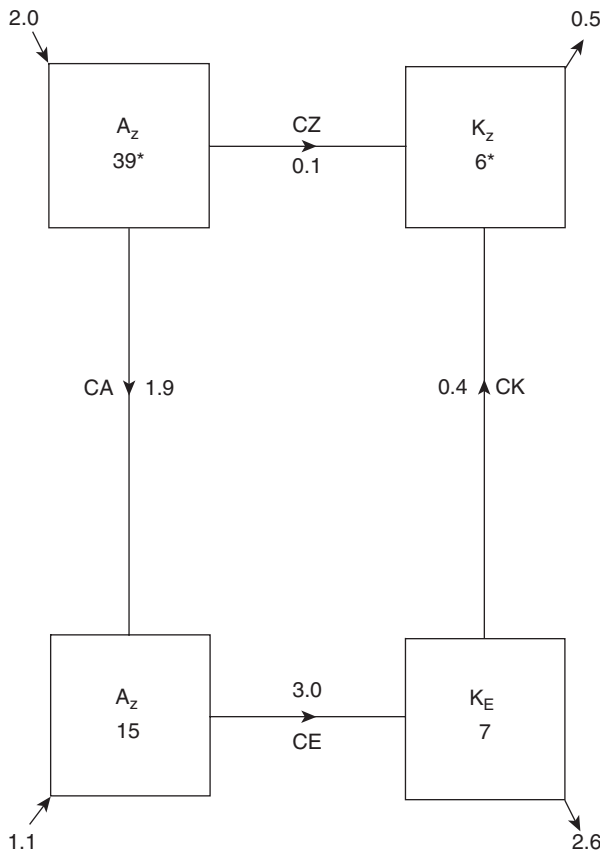

is obviously a primary track in the diagram. Barotropic instability follows the route K_z to K_e and is clearly negative (eddies feed K_e into the zonal mean flow).

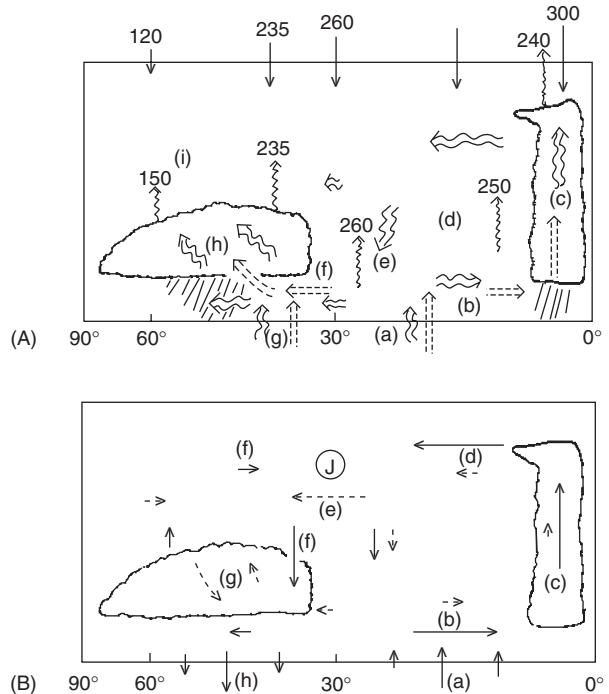

Figure 12 (A) Schematic meridional cross-sections of the atmospheric cycle of APE and heat. Arrow lengths are intended to suggest relative magnitudes. Single-shafted arrows depict radiation (straight for absorbed solar; wavy for terrestrial emitted to space) with representative numerical values given in $W m^{-2}$. Double-shafted arrows depict heat fluxes (dashed for latent; wavy for sensible heat). Letters correspond to distinct parts of the cycle. Solar radiation (a) is absorbed in the tropics and subtropics, then that heat energy is transported (b) equatorward. Latent heat (c) is converted to sensible heat in the ICZ then transported poleward (d) in the upper troposphere. Sinking in the Hadley cell (e) brings heat downward. Eddy fluxes (f) extract heat from the subtropics and are augmented by surface fluxes (g) at WBCs. Heat is mixed upward vertically (h) in frontal cyclones, whereupon a net loss occurs to space (i). (B) Similar to (A) except for the KE and momentum cycle. Arrow lengths are intended to suggest relative magnitude of momentum transport. Momentum transport in the troposphere is separated into mean meridional cells (solid arrows) and eddies (dashed arrows). Letters correspond to these parts of the cycle: Slowing down surface easterlies impart westerly momentum (a) into the tropical boundary layer. That momentum is transported equatorward (b) then upward (c) in the ICZ convection. The upper Hadley cell transports the momentum (d) poleward. Eddies further transport the momentum (e) poleward, out of the subtropics, while the Ferrel cell (f) both opposes the eddy flux and mixes some momentum downward. Frontal cyclones also have a net downward mixing (g) of westerly momentum that is lost by friction at the surface (h). The transport creates westerly momentum convergence in the subtropics and midlatitudes forming a subtropical jet (J) and a KE maximum there.

Figure 11 Energy “box” diagram showing reservoirs of zonal mean APE (A_z) and KE (K_z); eddy APE (A_e) and KE (K_e); net energy conversions (CA, CE, CK, CZ); and net diabatic generation or destruction. Global and annual average values indicated. The reservoirs are in units of $10^5 J m^{-2}$ and the conversions and diabatic processes have units of $W m^{-2}$. The conversions are given letter labels for future reference. The numbers are highly idealized and drawn from several sources with adjustments made to round off and balance input and output. The two numbers with asterisks are estimates made by the author using 1979–99 NCEP/NCAR reanalysis data.

friction removes K_e there must be net conversion of A_e to K_e . Depending on the estimated strength of F_e , G_e may be negative.

The box diagram for global energy shows:

- Relative sizes of energy “reservoirs” and conversions can be estimated. For example, in various studies K_e has been estimated to be more than half of the total KE, but between a fifth and a tenth of TE. A_e is a half to a quarter of the total APE.
- The flow of energy consists primarily of G_z to A_z to A_e to K_e to F_e .
- Different phenomena follow different paths. The conversion of A_z to K_z relates to Figure 2. Baroclinic instability, following the route A_z to A_e to K_e ,

The Energy Cycle

Energy in the general circulation follows paths from sources to sinks. Energy is mathematically cast in several useful forms and it is linked to several global constraints. To provide an overview of these diverse properties, **Table 1** and accompanying **Figure 12** summarize how energy in kinetic and potential forms flows in the general circulation. Heat and available potential energy are similar concepts and are compared in the table and figure. Similarly, momentum and KE may be considered together. The table and figure make clear that heat and momentum have similar circuits.

Westerly momentum is defined as positive, so frictional slowing of easterlies in the tropical boundary layer is a source of westerly momentum but a sink of KE. The low-level flow in the Hadley cells gains westerly momentum and transports it equatorward. Surface fluxes of heat and water provide a diabatic source of warmth and moisture to air parcels as they approach the ICZ. In the ICZ, westerly momentum is transported to the upper troposphere. Latent heat is released where the efficiency factor is large and positive, leading to strong diabatic generation of APE.

The upper branch of each Hadley cell transports westerly momentum poleward. Conservation of angular momentum builds the velocity relative to the Earth's surface, i.e., creating KE and providing one mechanism to create the subtropical jets. The poleward extent of the motion arises from interaction between the pressure gradient (poleward) and the Coriolis force (at right angles to the motion); these two forces would accelerate parcels along a trochoidal

path. Because the moist static energy (MSE) of the poleward moving air is much greater than the MSE of the equatorward moving air below, the Hadley cell has a net poleward transport of heat.

The subtropics are a transition between the convection-dominated tropical circulations and the frontal cyclone-dominated midlatitude circulations. Negative net radiation encourages parcels in the Hadley cell to sink, bringing down some westerly momentum as well as high potential temperatures. The frontal cyclones mix momentum and heat vertically. The vertical fluxes of heat by each cyclone and the vertical shear of the jet streams both are fundamental parts of the baroclinic instability mechanism.

In middle latitudes, air in the cyclones' warm sector has a poleward component of motion, while air in the cold sector moves equatorward: in both sectors eddy heat transport is poleward. Much precipitation accompanies the frontal cyclones with the bulk of it occurring in the warm sector, so there may be diabatic generation of eddy APE but loss of zonal APE. Further poleward, radiative cooling, especially from clouds, generates APE. Mature frontal cyclones develop momentum fluxes that converge upper-level westerly momentum, while their heat fluxes reduce the meridional temperature gradient on a zonal average. To maintain thermal wind balance a secondary circulation forms that also transports momentum (equatorward at upper levels). The westerly momentum mixed to the surface (for example in subsiding air of cold sectors) is removed by friction in the boundary layer, becoming a sink of westerly momentum and of KE.

Table 1 Stages in the APE (heat) and KE (momentum) energy cycle

<i>APE or heat flow</i>	<i>KE or momentum flow</i>
1. Solar and terrestrial radiation create excess heating in the tropics and a deficit poleward of 38°.	1. Westerly momentum is introduced in the tropics and is removed by friction in midlatitudes.
2. Result of item (1) is a poleward heat flux.	2. Result of item (1) is a poleward westerly momentum flux.
3. In midlatitudes eddies are the main mechanism for heat transport.	3. In midlatitudes eddies are the main mechanism for momentum transport.
4. The CA and CE conversions (see Figure 11) show that horizontal and vertical heat fluxes create eddy energy (baroclinic process). Latent heat release may also contribute.	4. Eddy momentum fluxes also provide sources and sinks of eddy kinetic energy from the CK conversion (see Figure 11). Since global average CK is positive, eddies must lose KE to the mean flow in the net.
5. Net radiation being positive causes the heat flux to increase with latitude in the subtropics. (More and more heat must be transported poleward to maintain quasi-steady PE.)	5. The flux of zonal mean KE keeps increasing with latitude in the subtropics where CK is positive. (More and more momentum must be transported poleward to maintain quasi-steady KE.)
6. The eddy heat flux is down the T gradient.	6. Eddy momentum flux is up the gradient of $[u] \cos^{-1} \phi$ at many latitudes.
7. The heat flux is maximum where net radiation is zero.	7. The flux of [KE] reaches a maximum where CK equals zero.
8. Poleward of the heat flux maximum there is cooling by net radiation.	8. Poleward of the angular velocity, $[u] \cos^{-1} \phi$, maximum, eddies remove energy from [KE] in the net.

See also

Baroclinic Instability (0076). **Dynamic Meteorology:** Balanced Flows and Potential-Vorticity Inversion (0140); Overview (0138); Primitive Equations (0139). **General Circulation:** Mean Characteristics (0154); Overview (0153). **Hadley Circulation** (0161). **Land/Atmosphere Interactions** (0476). **Ocean Circulation:** General Processes (0276). **Radiation Budget:** Planetary (0335); Surface (0336).

Further Reading

Dutton J and Johnson D (1967) The theory of available potential energy and a variational approach to atmospheric energetics. In: *Advances in Geophysics*, vol. 12, pp. 333–436. New York: Academic Press.

Grotjahn R (1993) *Global Atmospheric Circulations: Observations and Theories*. New York: Oxford University Press.

James I (1994) *Introduction to Circulating Atmospheres*. Cambridge: Cambridge University Press.

Johnson DR (1989) The forcing and maintenance of global monsoonal circulations: An isentropic analysis. In: *Advances in Geophysics*, vol. 31, pp. 43–316. San Diego, CA: Academic Press.

Karoly DJ and Vincent DG (1998) *Meteorology of the Southern Hemisphere*. Boston, MA: American Meteorological Society.

Peixoto JP and Oort AH (1992) *Physics of Climate*. New York: American Institute of Physics.